



ELECTRONIC SELECTOR

INSTRUCTION MANUAL

12	02-04-1999	
REL.	DATE	Verification and Approval R.T.

INDEX

DESCRIPTION OF DEVICE	Page	3
TECHNICAL SPECIFICATIONS	Page	3
101.06.03SEL SELECTOR CARD	Page	3
101.06.E1SEL EXPANSION CARD	Page	5

DESCRIPTION OF DEVICE

The SMS electronic selector is an electronic apparatus for counting floors in lift systems.

TECHNICAL SPECIFICATIONS

Power supply: 18-24 Vac or Vdc.

Maximum number of stops: 10 with 101.06.03SEL card, 16 by adding expansion card 101.06.E1SEL.

Opto-isolated inputs.

Relay outputs (5A-250V) used for signalling lift position.

Count with single or double bistable sensors.

Count incremented at 1 or 2 pulses.

LEDs indicating lift position.

Correction in case of mains power cut, by correction call to lowest floor.

Contact commanding doors to re-open

Lift stop number selection by dip-switch.

Contacts commanding directional auxiliary relays or contactors.

Dimensions: 160 x 220 mm.

Final test in controlled climate chamber at cycle of -20°C/+70°C for 48 hours.

Connected with detachable terminals.

101.06.03SEL SELECTOR CARD

Power supply :

Terminals 1 - 2 on terminal board M1.

Permissible voltage range: 18 to 24 V (Vac or Vdc).

The power circuit is protected by fuse F1.

Presence of 15V internal stabilised power is indicated by Led DL6.

Inputs :

Up/down count: terminals 3-4-5 on terminal board M1.

Terminal 3 is the common terminal.

A contact (N.O.) of a bistable switch is connected between terminals 3 and 4. It is used for counting in up direction.

A contact (N.O.) of a flip-flop switch is connected between terminals 3 and 5. It is used for counting in down direction.

When two bistable switches are used (one for up, the other for down), make sure that soldering point J1 is open.

When using one bistable switch only (for both up and down) connect its contact between terminals 3 and 4, then connect terminals 4 and 5 or close soldering point J1.

A single switch is used for <<low-speed>> systems, two separate switches are used for <<high-speed>> systems.

Input CS (3-5) in operation is indicated by Led DL1, input CD (3-5) in operation is indicated by Led DL2.

When connecting inputs CS and CD, remember to position setting jumper J3.

Up and down direction: terminals 6-7-8 on terminal board M1.

Common terminal: terminal 6

The contact (N.O.) of the up auxiliary relay or the up contactor to be connected between terminals 6 and 7.

The contact (N.O.) of the down auxiliary relay or the down contactor to be connected between terminals 6 and 8.

Input MS (up travel) in operation is indicated by Led DL3, input MD (down travel) in operation is indicated by Led DL4.

Floor relays: terminals 1- 10 on terminal board M3.

Floor relay contacts to be connected to terminals 1....10.

Always connect to terminal 10 the input corresponding to the top floor stop (for systems with less than 10 stops).

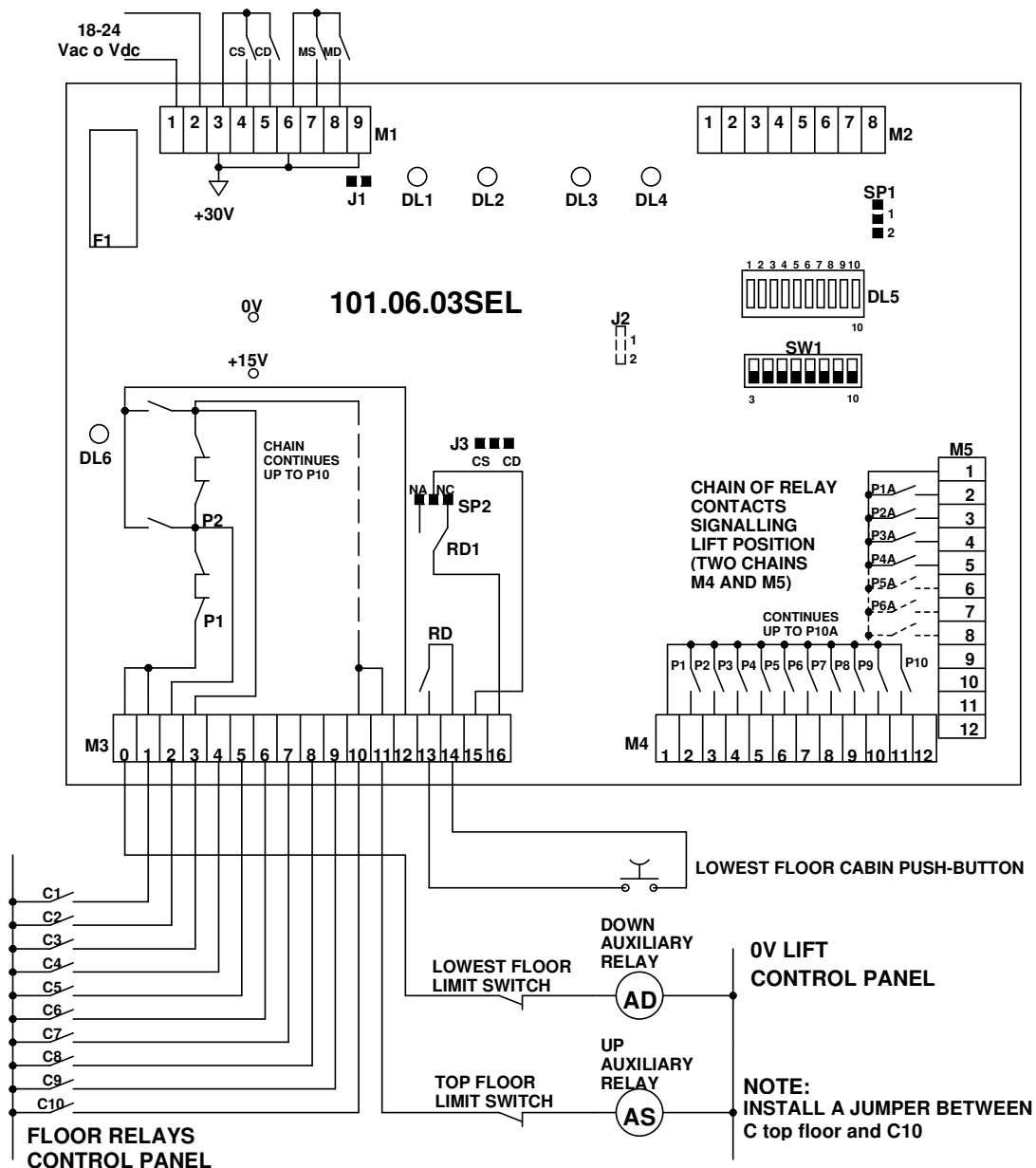

Outputs :

Floor relays: terminals 0 - 11 on terminal board M3.

The coil of the down auxiliary relay or contactor to be connected to terminal 0.

The coil of the up auxiliary relay or contactor (for systems with 10 stops max.) to be connected to terminal 11.

Lift position signals.

A set of contacts is available on terminal board M4, which may be used to signal lift position. Common terminal: #1. Contacts of relays (5A - 250V) are present on terminals 2...11.

A set of contacts is available on terminal board M5, which may be used as a second signal of lift positions or as a command for the warning gong. Common terminal: #1. Contacts of relays (5A - 250V) are present on terminals 2...11.

Correction call.

The N.O. contact of the RD relay is present on terminals 13 - 14 of terminal board M3. It can be used to operate the correction call (this contact closes when the correction call is operated). The contact must be connected in parallel to the contact of the cabin push-button used for calls to the lowest floor.

Contact of relay RD1 is present on terminals 15 - 16 of terminal board M3. This relay operates similarly to the RD relay mentioned above.

The contact for terminals 15 - 16 may be either N.O. or N.C. To choose, select weld SP2. Possible positions: NO to use the normally open contact, and NC to use the normally closed contact.

The correction call can be set as either PERMANENT or TIMED.

Signals :

DL1 - Led signalling CS (up count) input.
DL2 - Led signalling CD (down count) input.
DL3 - Led signalling MS (up direction travel) input.
DL4 - Led signalling MD (down direction travel) input.
DL5 - Led bar signalling lift position (positions from 1 to 10)
DL6 - Led signalling presence of +15V power.

Settings :

J1 - System with 1 or 2 bistable switches.
Soldering point closed = system with one switching sensor only.
Soldering point open = system with two switching sensors (1 for up, the other for down).
J2 - Correction call.
POS. 1 = Permanent correction call active until next up departure, and until lift reaches lowest level.
POS. 2 = Timed correction call active for 10 seconds after power up.
J3 - Count increment at 1 or 2 pulses.
POS. CS = Count increment at each pulse.
POS. CD = Count increment every 2 pulses.
SP1 = Selector set for 10 or 16 stops.
POS. 1 = selector set for stops in range 11 to 16 (with 101.06.E1SEL expansion card)
POS. 2 = selector set for ≤ 10 stops.
SP2 - RD1 relay contact for correction call.
POS. NA = Normally open RD1 relay contact.
POS. NC = Normally closed RD1 relay contact.
SW1 - Lift stop number selection.
Set to ON only the switch corresponding to the number of lift stops. POS.3 for 3-stop systems....position 10 for 10-stop systems.
Internal connections to expansion card 101.06.E1SEL.
Terminals of terminal board M2 to be connected to the relevant terminals on terminal board M6 of expansion card 101.06.E1SEL.
Terminal 11 of terminal board M3 to be connected to the terminal 1 on terminal board M7 of expansion card 101.06.E1SEL.
Terminal 1 of terminal board M4 to be connected to the terminal 1 on terminal board M8 of expansion card 101.06.E1SEL.
Terminal 1 of terminal board M5 to be connected to the terminal 1 on terminal board M9 of expansion card 101.06.E1SEL.

101.06.E1SEL EXPANSION CARD

Power supply :

The 101.06E1SEL card is powered by the internal connections described above.

Inputs :

Floor relay: terminals 2-7 on terminal board M7.
Floor relay contacts to be connected to terminals 2...7. Always connect to terminal 7 the input corresponding to the top floor stop (for systems with less than 16 stops).

Outputs :

The coil of the up contactor or auxiliary relay to be connected to terminal 8 (for systems with stops in range 11 to 16).
Lift position signals.
A set of contacts is available on terminal board M8, which maybe used for signalling lift position. Relay (5A - 250V) contacts are present on terminals 2....7.
A set of contacts is available on terminal board M9, which maybe used for signalling lift position. Relay (5A - 250V) contacts are present on terminals 2....7.

Signals :

DL1 - Led bar signalling lift position (positions from 11 to 16).

Settings :

SW1 - Lift stop number selection.

Set to ON only the switch corresponding to the number of lift stops. POS.11 for 11-stop systems....position 16 for 16-stop systems.

Make sure that all switches on the SW1 dip-switch of the selector card and the other switchws on the SW1 dip-switch of the expansion card are turned OFF.

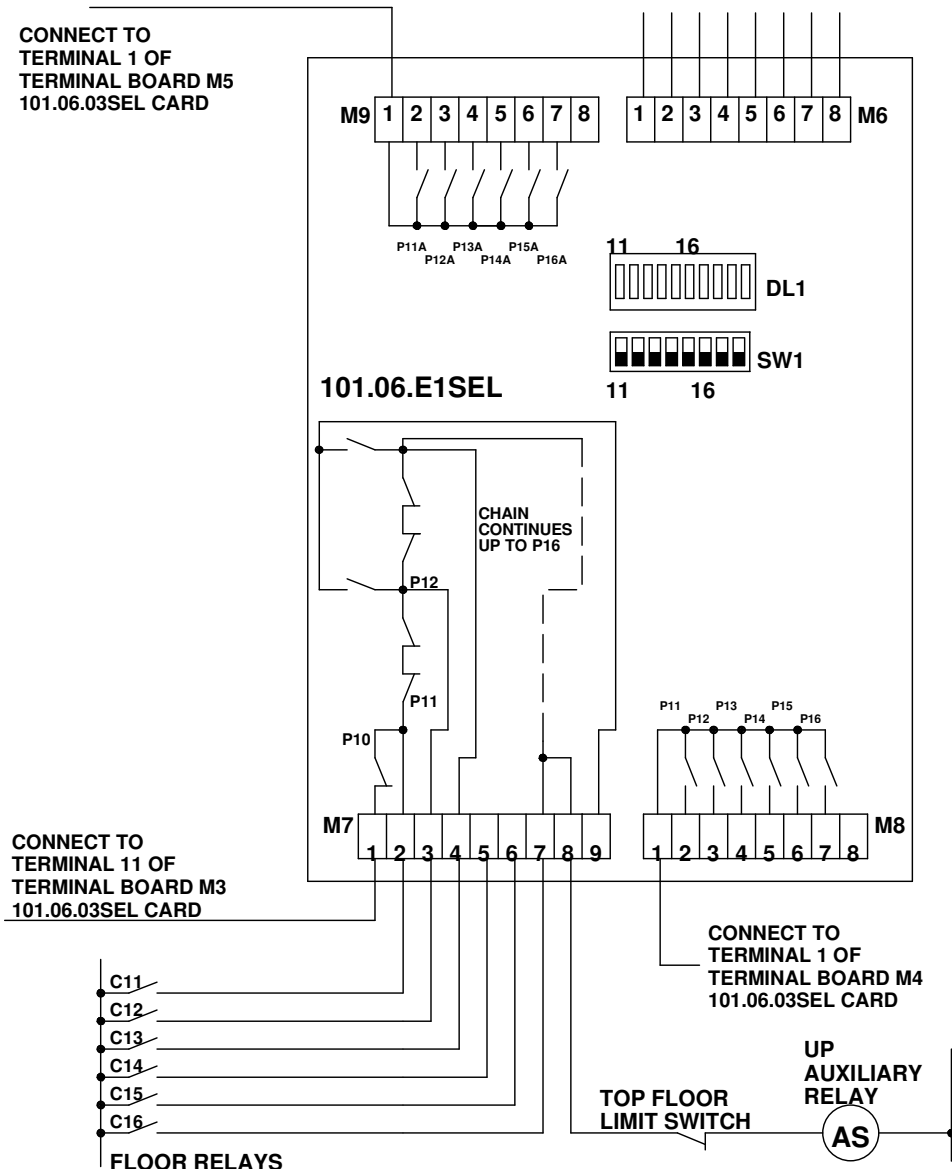

For any further information contact:

SMS SISTEMI e MICROSISTEMI s.r.l. (Gruppo SASSI HOLDING)

Cap. Soc. 260.000 i.v.

Via Guido Rossa, 46/48/50 40056 Crespellano BO

R.E.A 272354 CF - Reg. Imprese Bo 03190050371 P.IVA IT 00601981202

Tel. : +39 051 969037 Fax : +39 051 969303 Technical Service: +39 051 6720710

Web : www.sms.bo.it E-mail : sms@sms.bo.it